



T5

Plate Heat Exchanger

Applications

General heating and cooling duties.

Standard design

The plate heat exchanger consists of a pack of corrugated metal plates with portholes for the passage of the two fluids between which heat transfer will take place.

The plate pack is assembled between a fix frame plate and a movable pressure plate and compressed by tightening bolts. The plates are fitted with a gasket which seals the interplate channel and directs the fluids into alternate channels. The number of plates is determined by the flow rate, physical properties of the fluids, pressure drop and temperature program. The plate corrugations promote fluid turbulence and support the plates against differential pressure.

The plate and the pressure plate are suspended from an upper carrying bar and located by a lower guiding bar.

Connections are located in the frame plate or, if either or both fluids make more than a single pass within the unit, in the frame and pressure plates.

Typical capacities

Liquid flow rate

Up to 14 kg/s (222 gpm), depending on media, permitted pressure drop and temperature program.

Plate types

T5-B, T5-M

Frame types

FG

Working principle

Channels are formed between the plates and the corner ports are arranged so that the two media flow through alternate channels. The heat is transferred through the plate between the channels, and complete counter-current flow is created for highest possible efficiency. The corrugation of the plates provides the passage between the plates, supports each plate against the adjacent one and enhances the turbulence, resulting in efficient heat transfer.



T5-FG

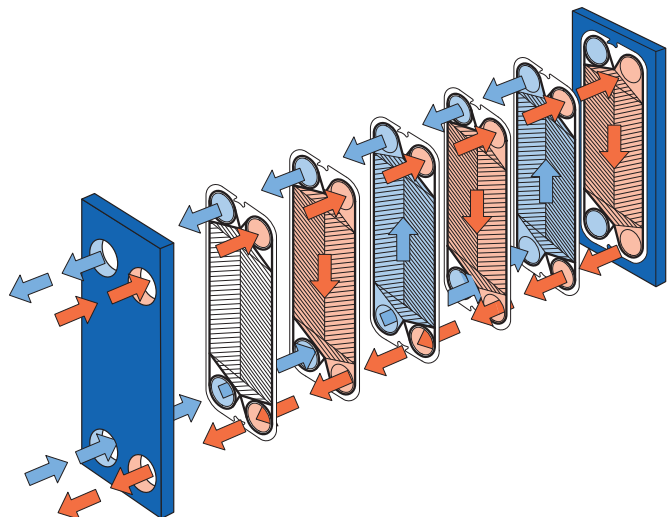

Flow principle of a plate heat exchanger

STANDARD MATERIALS

Frame plate

Mild steel, Epoxy painted

Nozzles

Carbon steel

Pipe: Stainless steel, titanium

Plates

Stainless steel Alloy 316 / Alloy 304

Titanium

Gaskets

Nitrile, EPDM

TECHNICAL DATA

Pressure vessel codes PED, ASME, pvcALS™

Mechanical design pressure (g) / temperature

FG	pvcALS™	1.6 MPa / 180°C
FG	PED	1.6 MPa / 160°C
FG	ASME	150 psig / 356°F

Maximum heat transfer surface

T5-B	7.1 m ² (76.4 sq.ft)
T5-M	4.4 m ² (47.4 sq.ft)

Connections

Straight threaded	Size 50 mm ISO G2"
Tapered threaded	Size 50 mm ISO R2", NPT2"
Threaded inlet port	Size 50 mm ISO-G2"

Dimensions

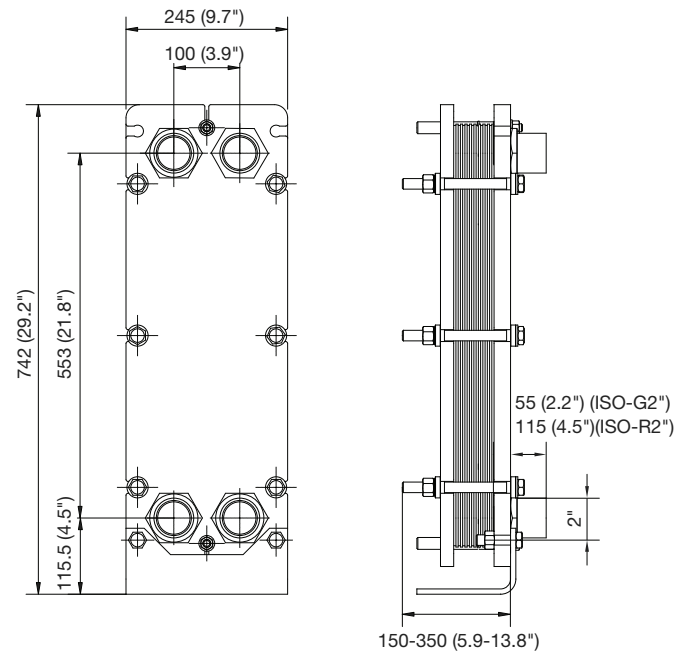

Measurements mm (inch)

Type	H	W	h
T5-FG	737 (29.0")	245 (9.6")	115.5 (4.5")

Particulars required for quotation

- Flow rates or heat load
- Temperature program
- Physical properties of liquids in question (if not water)
- Desired working pressure
- Maximum permitted pressure drop

How to contact Alfa Laval

Up-to-date AlfaLaval contact details for all countries are always available on our website on www.alfalaval.com