



M6

Plate heat exchanger

Applications

General heating and cooling duties. Heating by means of steam.

Standard design

The plate heat exchanger consists of a pack of corrugated metal plates with portholes for the passage of the two fluids between which heat transfer will take place.

The plate pack is assembled between a fix frame plate and a movable pressure plate and compressed by tightening bolts. The plates are fitted with a gasket which seals the interplate channel and directs the fluids into alternate channels. The number of plates is determined by the flow rate, physical properties of the fluids, pressure drop and temperature program. The plate corrugations promote fluid turbulence and support the plates against differential pressure.

The frame plate and the pressure plate are suspended from an upper carrying bar and located by a lower guiding bar, both of which are fixed to a support column.

Connections are located in the frame plate or, if either or both fluids make more than a single pass within the unit, in the frame and pressure plates.

Typical capacities

Liquid flow rate

Up to 16 kg/s (250 gpm), depending on media, permitted pressure drop and temperature program.

Water heating by steam

300 to 800 kW

Plate types

M6, M6-M and M6-MD

Frame types

FM, FG and FD

Working principle

Channels are formed between the plates and the corner ports are arranged so that the two media flow through alternate channels. The heat is transferred through the plate between the channels, and complete counter-current flow is created for highest possible efficiency. The corrugation of the plates provides the passage between the plates, supports each plate against the adjacent one and enhances the turbulence, resulting in efficient heat transfer.



M6-FG

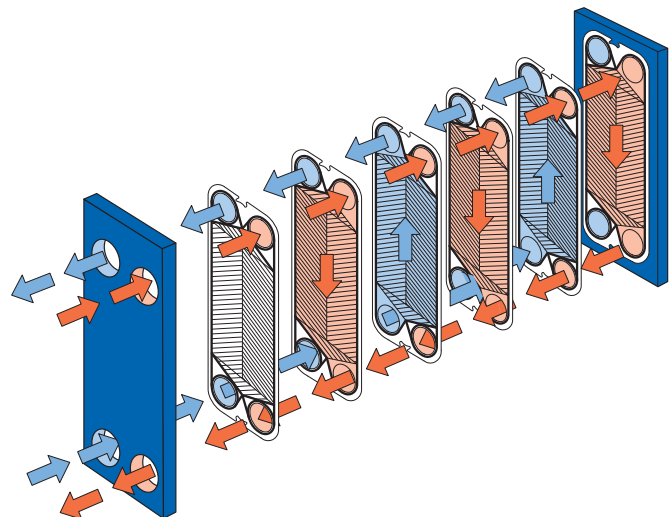

Flow principle of a plate heat exchanger

STANDARD MATERIALS

Frame plate

Mild steel, Epoxy painted

Nozzles

Carbon steel

Metal lined: Stainless steel, Titanium, Alloy 254 SMO, Alloy C276

Rubber lined: Nitrile, EPDM

Plates

Stainless steel: Alloy 316, Alloy 304. Alloy 254 SMO, Alloy C276, Titanium

Gaskets

Nitrile, EPDM, Viton®

Other grades and material available on request.

TECHNICAL DATA

Pressure vessel codes, PED, ASME, pvcALST™

Mechanical design pressure (g) / temperature

FM	pvcALST™	1.0 MPa / 180°C
FG	PED	1.6 MPa / 180°C
FG	ASME	162 psig / 482°F
FG	pvcALST™	1.6 MPa / 180°C
FD	PED, pvcALST™	2.5 MPa / 180°C
FD	ASME	351 psig / 482°F

Connections

Pipe connections (not for frame type FD)

	Size:	
Straight threaded	50 mm	ISO G2"
Tapered threaded	50 mm	ISO R2", NPT2"
Straight weld	50 mm	
Threaded inlet port	50 mm	ISO G2"
Grooved pipe	50 mm	2"

Flange connections

	Size:	
FM	pvcALST™	50 mm DIN/GB/GOST PN10, ASME Cl. 150, JIS 10K
FG	PED	50 mm DIN PN16, ASME Cl. 150
FG	ASME	2" ASME Cl. 150
FG	pvcALST™	50 mm DIN/GB/GOST PN16, ASME Cl. 150, JIS 16K
FD	PED	50 mm DIN PN25, ASME Cl. 300
FD	ASME	2" ASME Cl. 300
FD	ALS	50 mm DIN, GB, GOST PN25, JIS 20K

Dimensions

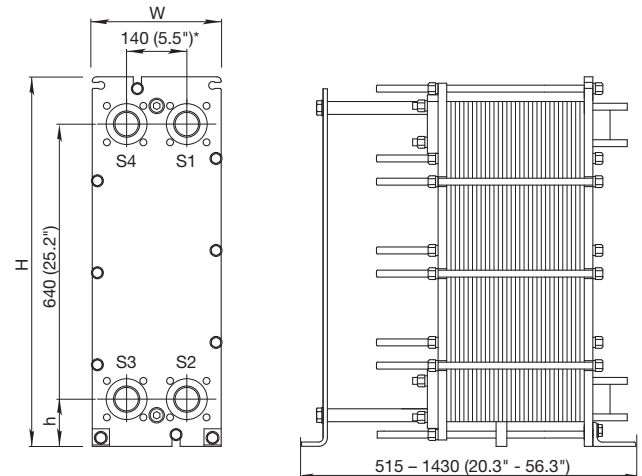

* Displacement of some connection types occur.

Measurements mm (inch)

Type	H	W	h
M6-FM	920 (36.2")	320 (12.6")	140 (5.5")
M6-FG	920 (36.2")	320 (12.6")	140 (5.5")
M6-FD	940 (37.0")	330 (13.0")	150 (5.9")

The number of tightening bolts may vary depending on pressure rating.

Maximum heat transfer surface

38 m² (400 sq. ft)

Particulars required for quotation

- Flow rates or heat load
- Temperature program
- Physical properties of liquids in question (if not water)
- Desired working pressure
- Maximum permitted pressure drop
- Available steam pressure

How to contact Alfa Laval

Up-to-date AlfaLaval contact details for all countries are always available on our website on www.alfalaval.com