

ZU4-Series, Portable Electric Pumps

▼ Shown from left to right: ZU4304ME, ZU4420SE-H, ZU4304PE-K



- High-efficiency two-speed pump design – higher oil flow and bypass pressure
- Powerful 1,25 kW universal electric motor provides high power-to-weight ratio and excellent low-voltage operating characteristics
- High-strength, moulded composite shroud protects motor and electronics, while providing an ergonomic, non-conductive handle for easy transport.

Pro-Series models only

- * Back-lit LCD readout provides pressure display and a number of diagnostics and readout capabilities never offered on a portable pump before
 - pump usage information, hour and cycle counts
 - self-test, diagnostic and read-out capabilities
 - pressure readout and auto-mode pressure settings.

Z Tough.
Dependable.
Innovative.
CLASS



ZU4-Series Features and Options

For special requirements see factory installed features and options.

Page: **84**

▼ COMMON PUMP MODELS

For technical information and other options see next page.

BASIC PUMP TYPES	
Select the model that suits your application. For special requirements contact your Enerpac office.	
Manual Valve	
<ul style="list-style-type: none"> • Ideal choice for most applications. • Manual valve control, for single-acting or double-acting applications. • Motor control on shroud. 	
Manual Valve with Pendant *	
<ul style="list-style-type: none"> • For light production and lifting applications. • Manual valve for single- or double-acting cylinders. • Manual valve with power seat (VM43LPS), ideal for post-tensioning applications. 	
Dump Valve *	
<ul style="list-style-type: none"> • Ideal for punching, crimping and cutting. • For use when load-holding is not required. 	
Solenoid Valve *	
<ul style="list-style-type: none"> • Ideal for lifting applications and where remote control is required. • With VE32 valve, motor only runs during the advance function, while holding and retracting, the motor is off. • Motor runs continuously on pumps with VE33 and VE43 valves. 	

* Low-voltage control pendant with 3 m. cord controls valve and motor.

ZU4-Series, Electric Pumps



Z-Class – A Pump For Every Application

Patented Z-Class pump technology provides high by-pass pressures for increased productivity – important in applications using long hose runs and high pressure-drop circuits, like heavy lifting or certain double-acting tools.

Enerpac ZU4-Series Pumps are built to power small to large-sized cylinders or hydraulic tools, or wherever high-speed, intermittent duty, remote hydraulic power is needed.

Classic Electric Pump

- The Classic has traditional electro-mechanical components (transformers, relays and switches) in place of solid-state electronics.

The Classic delivers durable, safe and efficient hydraulic power for demanding markets like construction, post-tensioning and foundation repair.

Standard Electric Pump

- For applications that do not require digital display features of the Premium Pump. Available in all manual or jog versions.

Pro Electric Pump

- Digital (LCD) display features a built-in hour meter and shows self-diagnostic, cycle-count and low voltage warning information.

Pressure can also be displayed when the pump is equipped with an optional pressure transducer.



ZU4 Series



Reservoir Capacity:

4 - 40 litres

Flow at Rated Pressure:

1,0 l/min

Motor Size:

1,25 kW

Maximum Operating Pressure:

700 bar

Pump type	Used with Cylinder		Valve Funktion			Valve Type ¹⁾	Pump Control	Useable Oil Capacity (litres)	Model Number 230 V - 1 phase - 50 Hz ²⁾			Pro Electric Weight ³⁾ (kg)
									Classic Electric	Standard (STD) Electric	Pro Electric (incl. LCD)	
	●		●		●	VM32	Manual	4,0	ZU4204RE	ZU4204ME	ZU4204LE	27
	●		●		●	VM32	Manual	8,0	ZU4208RE	ZU4208ME	ZU4208LE	32
	●		●	●	●	VM33	Manual	8,0	ZU4308RE	ZU4308ME	ZU4308LE	32
	●		●	●	●	VM33	Manual	20,0	ZU4320RE	ZU4320ME	ZU4320LE	50
		●	●	●	●	VM43	Manual	8,0	ZU4408RE	ZU4408ME	ZU4408LE	32
		●	●	●	●	VM43	Manual	20,0	ZU4420RE	ZU4420ME	ZU4420LE	50
	●		●		●	VM32	Remote (Man.)	4,0	ZU4204PE	ZU4204JE	ZU4204KE	27
	●		●		●	VM32	Remote (Man.)	8,0	ZU4208PE	ZU4208JE	ZU4208KE	32
	●		●		●	VM32	Remote (Man.)	20,0	ZU4220PE	ZU4220JE	ZU4220KE	50
	●		●	●	●	VM33	Remote (Man.)	8,0	ZU4308PE	ZU4308JE	ZU4308KE	32
		●	●	●	●	VM43	Remote (Man.)	8,0	ZU4408PE	ZU4408JE	ZU4408KE	32
		●	●	●	●	VM43	Remote (Man.)	20,0	ZU4420PE	ZU4420JE	ZU4420KE	50
	●		●		●	VE32D	Remote	4,0	N/A	N/A	ZU4104DE	29
	●		●		●	VE32D	Remote	8,0	N/A	N/A	ZU4108DE	33
	●		●		●	VE32D	Remote	20,0	N/A	N/A	ZU4120DE	51
						-	-	-	-	-	-	-
						-	-	-	-	-	-	-
						-	-	-	-	-	-	-
	●		●		●	VE32	Remote	4,0	N/A	N/A	ZU4204SE	29
	●		●		●	VE32	Remote	8,0	N/A	N/A	ZU4208SE	33
	●		●	●	●	VE33	Remote	8,0	N/A	N/A	ZU4308SE	39
		●	●	●	●	VE43	Remote	8,0	N/A	N/A	ZU4408SE	39
		●	●	●	●	VE43	Remote	20,0	N/A	N/A	ZU4420SE	56
						-	-	-	-	-	-	-
						-	-	-	-	-	-	-
						-	-	-	-	-	-	-

¹⁾ See valves section for technical information on valve types. ²⁾ See custom order matrix on page 87 for other voltage options.

³⁾ Subtract 1,4 kg for Standard (STD) Electric models.



Pressure Transducer *

- More durable than analog gauges (against mechanical and hydraulic shock)
- More accurate than analog gauges (0,5% full scale of pump)
- Calibration can be fine tuned for certification
- "Set pressure" feature turns off motor at user defined pressure (or shifts valve to neutral on models with VE33/VE43 valves)
- Display pressure in bar, psi or MPa.

* Requires LCD Electric

Accessory Kit Model Number	Adjustable Pressure Range (bar)	Switch-point repeatability	Dead-band (bar)
ZPT-U4 *	3,5 - 700	± 0,5%	3,5

* Add suffix **T** for factory installation.

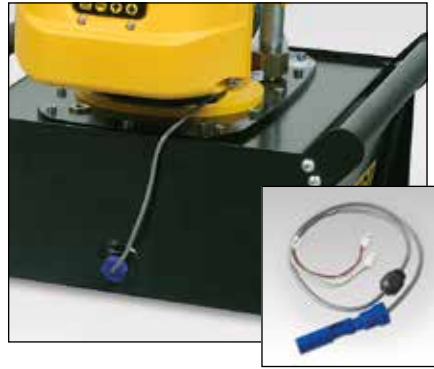

Level/Temperature Switch

- Ensures feedback on pump oil level and temperature
- Drop-in design allows for easy installation to pump reservoir
- Plugs directly into pump electrical enclosure
- Built-in thermal sensing shuts off pump when unsafe operating temperature is reached
- Oil level switch shuts down pump before oil reaches an unsafe operating level.

Model Number	Operating Temperature (°C)	Maximum Pressure (bar)	 (kg)
ZLS-U4 *	5-110	10	0,1

* Add suffix **L** for factory installation.



Hoses

Enerpac offers a complete line of high-quality hydraulic hoses. To ensure the integrity of your system, specify only Enerpac hydraulic hoses.

Page: 116



Gauges

Minimize the risk of overloading and ensure long, dependable service from your equipment. Refer to the System Components section for a full range of gauges.

Page: 124



Foot Switch

- Hands-free remote control on solenoid dump and 3-position valves
- With 3 metres cord.

Accessory Kit Modelnr.	Can be used on ZU4-Series Pumps with
ZCF-2 *	Solenoid VE-Series valves

* Add suffix **U** for factory installation.



Roll Cage

- Protects pump
- Provides greater pump stability.

Accessory Kit Modelnr.	Fits on reservoir
ZRC-04 *	4 and 8 litres ¹⁾
ZRC-04H *	4 and 8 litres ²⁾
ZRB-10 *	10 litres
ZRB-20 *	20 litres
ZRB-40 *	40 litres

* Add suffix **R** for factory installation.

¹⁾ Without heat exchanger

²⁾ With heat exchanger.



Skid Bar

- Provides easy two-hand lift
- Provides greater pump stability on soft or uneven surfaces.

Accessory Kit Modelnr.	Fits on reservoir	 (kg)
SBZ-4 *	4 and 8 l without heat exchanger	2,2
SBZ-4L *	4 and 8 l with heat exchanger	3,2

* Add suffix **K** for factory installation.

ZU4-Series, Options & Accessories



ZU4-Series Options

Accessory Kits can be installed by the customer.

See chart below for all possible options on ZU4-Series pumps:

- Classic Electric,
 - Standard (STD) Electric (no LCD)
 - Pro Electric (with LCD).
- Refer to page 87 for ordering matrix.

ZU4-Series Options	Factory Installed			Accessory Kits		
	Classic Electric	Standard Electric	Pro Electric	Classic Electric	Standard Electric	Pro Electric
Return Line Filter	F	F	F	ZPF	ZPF	ZPF
Skid Bar ¹⁾	K	K	K	SBZ	SBZ	SBZ
Roll Cage	R	R	R	ZRC	ZRC	ZRC
Heat Exchanger	H	H	H	ZHE	ZHE	ZHE
1000 bar Pressure Gauge	G	G	G	G	G	G
Pressure Transducer	-	-	T	-	-	ZPT-U4
Level/Temperature Switch	-	-	L	-	-	ZLS-U4
Foot Switch	-	-	U	-	-	ZCF-2

¹⁾ Skid Bar not in combination with Roll Cage.

ZU4 Series



Reservoir Capacity:

4 - 40 litres

Flow at Rated Pressure:

1,0 l/min

Motor Size:

1,25 kW

Maximum Operating Pressure:

700 bar



25 Micron Return Line Filter

- Removes contaminants from return oil flow
- By-pass valve prevents damage if filter is dirty
- With maintenance indicator.

Accessory Kit Modelnr.	Maximum Pressure (bar)	Maximum Oil Flow (l/min)	By-pass Setting (bar)
ZPF *	13,8	45,4	1,7

* Add suffix **F** for factory installation.



Heat Exchanger

- Removes heat from by-pass oil to provide cooler operation
- Stabilizes oil viscosity, increasing oil life and reduces wear of pump and other hydraulic components.

Accessory Kit Nr.	Can be used on	(kg)
ZHE-U115 *	115 V pumps	4,1
ZHE-U230 *	230 V pumps	4,1

* Add suffix **H** for factory installation.



Heat Exchanger

Can be factory installed on ZU4-Series Classic, Standard Electric and Pro Electric models.

- Extends system life.
- Stabilizes oil temperature at a maximum of 54 °C at 21 °C ambient temperature.

Do not exceed maximum oil flow and pressure ratings. Heat exchanger is not suitable for water-glycol or high water based fluids.

Thermal Transfer *		Maximum Pressure	Maximum Oil Flow	Voltage
Btu/h	kJoule	(bar)	(l/min)	(VDC)
900	950	20,7	26,5	12

* At 1,9 l/min at 21 °C ambient temperature.

ZU4, Specifications and Dimensions

OIL FLOW VERSUS PRESSURE

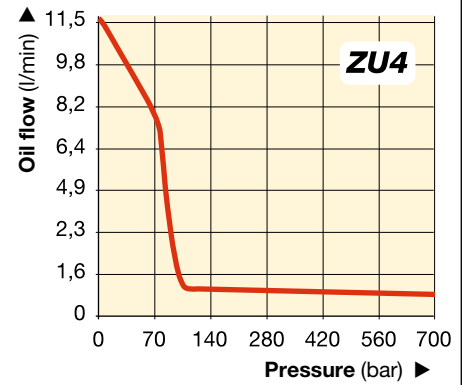

ZU4-SERIES PERFORMANCE CHART

Motor Size (kW)	Output Flow Rate at 50 Hz (l/min)				Motor Electrical Specifications (Volts-Ph-Hz)	Sound Level (dBA)	Relief Valve Adjustment Range (bar)
	7 bar	50 bar	350 bar	700 bar			
1,25	11,5	8,8	1,2	1,0	115-1-50/60 230-1-50/60	85-90	140-700

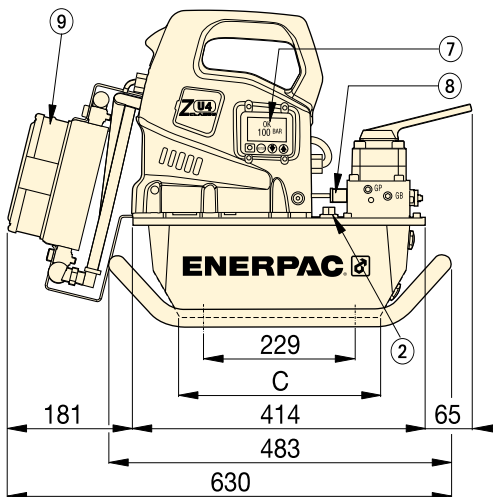

ZU4-Series with 4 and 8 litres reservoirs

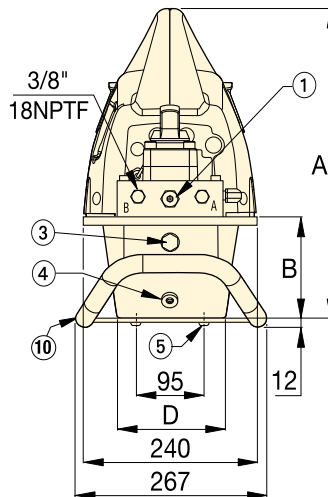

3/8"-18 NPTF Advance and Retract Ports

- ① User adjustable relief valve
- ② Oil fill port SAE #10 7/8"-14 UNF-2B
- ③ Oil level sight gauge
- ④ Oil drain 1/2" NPTF
- ⑤ M8, 6 mm deep
- ⑥ Handles on all 10, 20 and 40 litres reservoirs.

Options (see chart on page 85):

- ⑦ Back-lit LCD Electric
- ⑧ Pressure transducer
- ⑨ Heat Exchanger
- ⑩ Skid Bar
Fits 4 and 8 litres reservoirs
- ⑪ Handle guard installed on all 10, 20 and 40 litres reservoirs
- ⑫ Reservoir handles (not shown) included on all 10, 20 and 40 litres reservoirs.

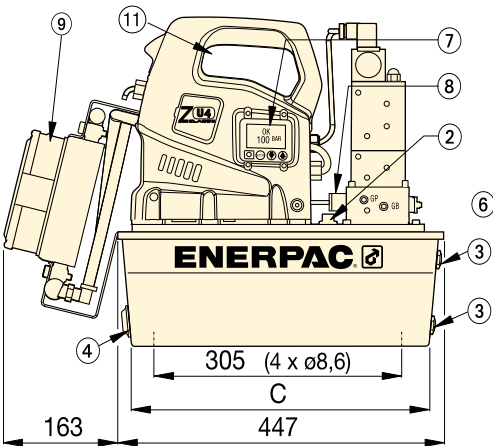

ZU4-Series with 10, 20 and 40 litres reservoirs
(left view shown without side handle)

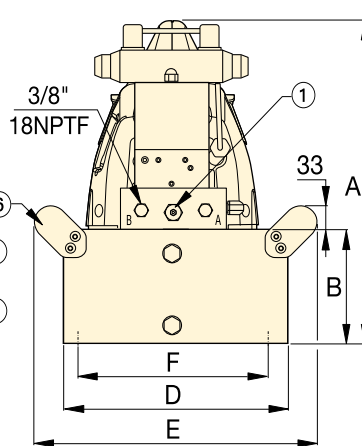

Pump Dimensions (mm)

Usable Reservoir Capacity (litres)	A	B	C	D	E	F
4,0	424	142	279	152	-	-
8,0	424	142	279	206	-	-
10,0	439	157	413	305	384	279
20,0	465	180	413	422	500	396
40,0	551	269	399	503	576	480

ZU4-Series, Pump Ordering Matrix

CUSTOM BUILD YOUR ZU4-SERIES PUMP

If the ZU4-Series pump that would best fit your application cannot be found in the chart on page 83, you can easily build your custom ZU4-Series pump here.

▼ This is how a ZU4-Series pump model number is built up:

Z	U	4	1	04	D	E	-	H	K	T
1	2	3	4	5	6	7		8		
Product Type	Motor Type	Flow Group	Valve Type	Reservoir Size	Valve Operation	Voltage		Options and Accessories		

1 Product Type

Z = Pump Series

2 Motor Type

U = Universal electric motor

3 Flow Group

4 = 1,0 l/min @ 700 bar

4 Valve Type (see page 110-111 for more details)

- 1** = Dump (VE32D)
- 2** = 3 way/2 position manual or electric (VM32 or VE32)
- 3** = 3 way/3 position manual or electric (VM33 or VE33)
- 4** = 4 way/3 position manual or electric (VM43 or VE43)
- 6** = 3 way/3 position locking manual w/po check (VM33L)
- 7** = 3 way/2 position manual (VM22)
- 8** = 4 way/3 position locking manual w/po check (VM43L)
- 9** = 4 way/3 position manual w/power seating (VM43-LPS)

5 Reservoir Size (useable capacity)

- 04** = 4 litres
- 08** = 8 litres
- 10** = 10 litres ¹⁾
- 20** = 20 litres ¹⁾
- 40** = 40 litres ¹⁾

¹⁾ reservoir includes side handles.

6 Valve Operation

- D** = Dump (solenoid valve w/pendant and LCD Electric)
- J** = Jog (manual valve w/pendant and Standard Electric (i.e. w/o LCD))
- K** = Jog (manual valve w/pendant and LCD Electric)
- L** = Manual valve w/LCD Electric (w/o pendant)
- P** = Manual valve w/pendant and classic electric (i.e. w/o LCD)
- R** = Manual valve w/Classic electric (i.e. w/o LCD) [w/o pendant]
- M** = Manual valve w/Standard Electric (i.e. w/o LCD) [w/o pendant]
- S** = Solenoid valve w/pendant and LCD Electric

7 Voltage

- B** = 115V, 1 ph, 50/60Hz
- E** = 208-240V, 1 ph, 50/60 Hz (w/European plug and CE EMC compliant)
- I** = 208-240V, 1 ph, 50/60 Hz (w/NEMA 6-15 plug)

8 Options and Accessories (see page 85 for possibilities)

- F** = Filter
- G** = 0-1000 pressure gauge (ø 63,5 mm) ¹⁾
- H** = Heat exchanger
- K** = Skid Bar (4 and 8 litres reservoirs only)
- L** = Level/temperature switch ²⁾³⁾
- N** = No reservoir handles (includes lifting eyes)
- R** = Roll Cage
- T** = Pressure transducer ²⁾
- U** = Foot switch

¹⁾ Pressure gauge not available on pump models with pressure transducer

²⁾ These options require Pro Electric

³⁾ Not available on 4 and 8 litres reservoirs

ZU4 Series



Reservoir Capacity:

4 - 40 litres

Flow at Rated Pressure:

1,0 l/min

Motor Size:

1,25 kW

Maximum Operating Pressure:

700 bar



Speed Chart

To determine how a specific pump will operate your cylinder, see the Pump-Cylinder Speed Chart in the 'Yellow Pages'.

Page: **255**



Ordering Example

Model Number:
ZU4408DE-HKT

ZU4408DE-HKT is a Pro Electric model pump with LCD, 1,0 l/min oil flow at 700 bar, pump with a dump valve, an 8 liter reservoir, operates on 230V, heat exchanger, pressure transducer and skid bar.



Torque Wrench Pumps and Hoses

Enerpac system matched air and electric torque wrench pumps provide control to operate hydraulic torque wrenches.

Page: **200**