

▼ Shown from left to right: CLP-2002, CLP-5002



- Extremely low height for use in confined areas
- Lock nut for positive and safe mechanical load holding over a long period of time
- Single-acting, load return
- Optional special synthetic coating for improved corrosion resistance and lower friction for smoother operation
- Overflow port functions as a stroke limiter
- CR-400 coupler and dust cap included on all models.

▼ Only the extreme low height CLP-cylinder fits in this confined area to lift the construction. The V-82 needle valve is used to control cylinder speed during lifting and lowering.



## The Shortest Power Lifter



### Tilt Saddles

All CLP-Series cylinders include integral tilt saddles with maximum tilt angles up to 5°.



### Gauges

Minimize the risk of overloading and ensure long, dependable service from your equipment. Refer to the

System Components Section for a full range of gauges.

Page: 114



### Hoses

Enerpac offers a complete line of high quality hydraulic hoses. To ensure the integrity of your system, specify only Enerpac hydraulic hoses.

Page: 116

Cylinder Capacity	Stroke	Model Number *	Cylinder Effective Area	Oil Capacity
ton (kN)	(mm)		(cm <sup>2</sup> )	(cm <sup>3</sup> )
60 (606)	50	CLP-602	86,6	432
100 (1027)	50	CLP-1002	146,8	734
160 (1619)	45	CLP-1602	231,3	1040
200 (1999)	45	CLP-2002	285,6	1285
260 (2567)	45	CLP-2502	366,8	1650
400 (3916)	45	CLP-4002	559,5	2517
520 (5114)	45	CLP-5002	730,6	3287

\* Please contact Enerpac for ordering information for CLP-cylinders with special synthetic coating.

# Single-Acting, Pancake Lock Nut Cylinders



## Speed Chart

See the Enerpac Cylinder Speed Chart in our 'Yellow Pages' to determine your approximate cylinder speed.

Page: 255



## Longer Stroke Lock Nut Cylinders

For longer stroke lock nut applications **CLL-Series** cylinders are the perfect choice.

Page: 48

## CLP Series



Capacity:

**60 - 520 ton**

Stroke:

**45 - 50 mm**

Maximum Operating Pressure:

**700 bar**

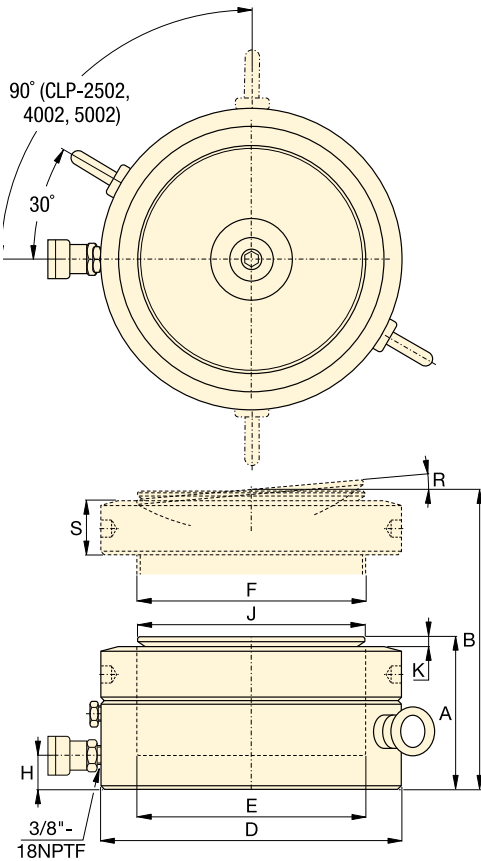

**ALL CLP-SERIES CYLINDERS REQUIRE A SOLID LIFTING SURFACE FOR CORRECT SUPPORT.**

**THE USE OF PANCAKE CYLINDERS ON SURFACES SUCH AS SAND, MUD OR DIRT, MAY RESULT IN CYLINDER DAMAGE!**



**WRONG!**

Rough soil

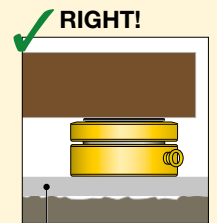

**RIGHT!**

Flat lifting surface

For more safety instructions see our 'Yellow Pages'.

Page: 246

Collapsed Height	Extended Height	Outside Diameter	Cylinder Bore Diameter	Plunger Diameter	Base to Advance Port	Saddle Diameter	Saddle Protrusion from Plgr.	Saddle Max. Tilt Angle	Lock Nut Height	(kg)	Model Number *
A (mm)	B (mm)	D (mm)	E (mm)	F (mm)	H (mm)	J (mm)	K (mm)	R	S (mm)		
125	175	140	105,0	Tr 104 x 4	19	96	6	5°	28	15	CLP-602
137	187	175	136,7	Tr 136 x 6	21	126	8	5°	31	26	CLP-1002
148	193	220	171,6	Tr 171 x 6	27	160	9	5°	40	44	CLP-1602
155	200	245	190,7	Tr 190 x 6	30	180	10	5°	43	57	CLP-2002
159	204	275	216,1	Tr 216 x 6	32	200	11	5°	44	74	CLP-2502
178	223	350	266,9	Tr 266 x 6	39	250	11	4°	55	134	CLP-4002
192	237	400	305,0	Tr 305 x 6	48	290	10	3°	62	189	CLP-5002