

▼ From left to right: S3000, S6000, S1500



Rigid Steel Design

The *Professional* Square Drive Solution

Simplicity

- Includes handle to improve tool handling and safety
- 360° click-on, multi-position reaction arm
- Push button square drive release for quickly reversing the square drive for tightening or loosening
- Fine tooth ratchet prevents tool “lock-on”
- Single 360° hydraulic swivel manifold, complete with screw lock couplings, increases wrench and hose maneuverability.

Design

- Compact, high-strength uni-body construction for a small operating radius
- Robust design with minimal parts enables easy on-site maintenance without special tools
- Lightweight, ergonomic design for easy handling and an easy fit, even in applications where access is limited
- Optimised strength-to-weight ratio
- Fast operation due to the large nut rotation per wrench cycle (35 degree rotation angle) and rapid return stroke.

Reliability

- All wrenches are nickel-plated for excellent corrosion protection and improved durability in harsh environments.

Accuracy

- Constant torque output provides high accuracy across the full stroke
- Accuracy of $\pm 3\%$ can be achieved because the Uni-Body construction reduces internal deflections.



S-Series, Torque Wrenches

The most advanced and safe torque wrenches on the market. To ensure that the tools you buy meet our own exacting requirements, during the design process every prototype was put through finite element stress analysis, photo-elastic modeling, rigorous cyclic testing and strain gauging.

The S-Series torque wrenches are tested and certified according to the Directive on Machinery: 2006/42/EC, and ATEX, Directive on potentially explosive atmospheres: 94/9/EC with the ratings of: CE Ex II 2 GD cT4.

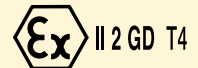

TSP - Pro Series Swivel

Featuring Tilt & Swivel technology the TSP provides 360° X-axis rotation and 160° Y-axis rotation.

How to Order

Order as an accessory which can be fitted to existing S-Series wrenches. Factory fitted: add suffix "P" to the wrench model number: **S1500P**.

Page:  9



Torque Wrench Hoses

Use Enerpac THQ-700 Series torque wrench hoses with S-Series torque wrenches to ensure the integrity of your hydraulic system.

6 m long, 2 hoses	THQ-706T
12 m long, 2 hoses	THQ-712T

Double-Acting Square Drive Hydraulic Torque Wrenches

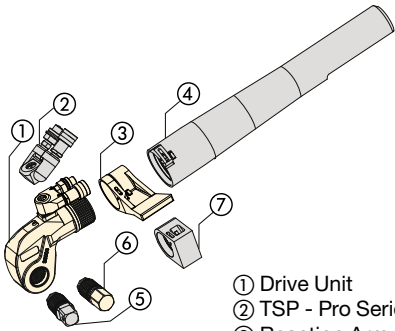

- ① Drive Unit
- ② TSP - Pro Series Swivel
- ③ Reaction Arm
- ④ Extended Reaction Arm
- ⑤ Square Drive
- ⑥ Allen Key Drive
- ⑦ Short Reaction Arm



Select the Right Torque
Choose your Enerpac Torque Wrench using the untightening rule of thumb: Loosening torque equals about 250% of tightening torque.

S Series



Maximum Torque at 690 bar:
34.099 Nm

Square Drive Range:
3/4 - 2 1/2 inch

Nose Radius:
25,0 - 63,5 mm

Maximum Operating Pressure:
690 bar

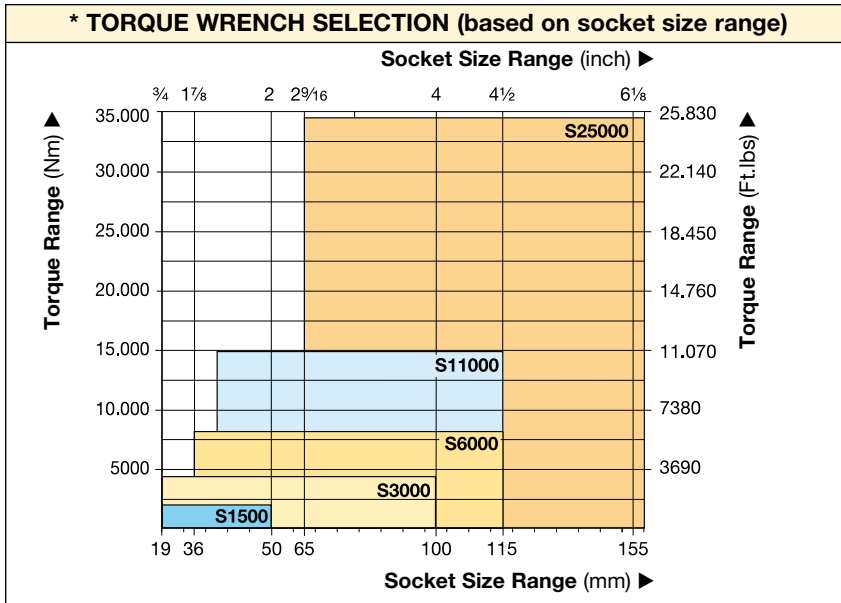

* Additional socket sizes available upon request. See page 10 for BSH-Series sockets.

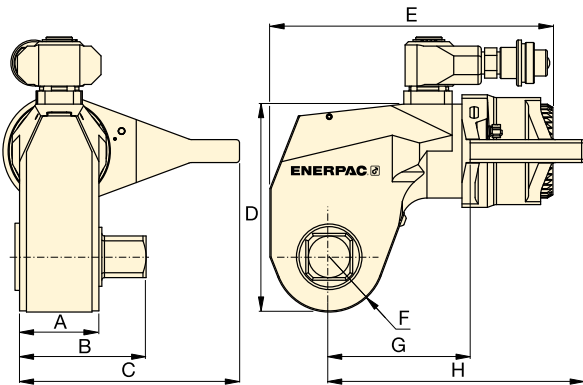



The rigid steel design of S-Series torque wrenches guarantee durability, reliability and safety. These wrenches can be powered by the portable ZU4T-Series pumps.



Torque Wrench and Pump Selection Matrix
For optimum speed and performance see the torque wrench and pump matrix.

Page: **32**



Maximum Torque at 690 bar		Square Drive		Torque Wrench Model Nr. *	Dimensions (mm)								 (kg)	
		Size (inch)	Model No. (included with wrench)		A	B	C	D	E	F	G	H		
Nm	(Ft.lbs)													
1898	1400	3/4"	SD15-012	S1500	39	65	108	95	136	25	72	119	2,7	
4339	3200	1"	SD30-100	S3000	48	80	134	125	173	33	91	159	5,0	
8148	6010	1 1/2"	SD60-108	S6000	55	92	167	155	193	41	113	186	8,5	
14.914	11.000	1 1/2"	SD110-108	S11000	72	114	196	187	228	50	133	226	15,0	
34.099	25.150	2 1/2"	SD250-208	S25000	89	143	244	241	287	64	182	291	31,0	

* To order a S-series wrench fitted with the TSP swivel, suffix the model number with "P". e.g., **S1500P**. Minimum output torque is 10% of maximum torque. See "Yellow Pages" section for torque conversions and tables of pressure versus torque (pages 77-78).

SDA-Series, Allen Key Drives

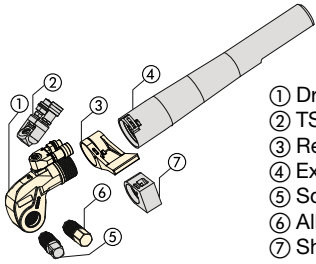

- ① Drive Unit
- ② TSP - Pro Series Swivel
- ③ Reaction Arm
- ④ Extended Reaction Arm
- ⑤ Square Drive
- ⑥ Allen Key Drive
- ⑦ Short Reaction Arm

Maximum Torque at 690 bar:

34.099 Nm

Square Drive Range:

3/4 - 2 1/2 inch

Hexagon Size Allen Drive:

14 - 85 mm | 1/2-2 1/4"

For
S
Series



▼ SELECTION CHART

TORQUE WRENCH	OPTIONAL ALLEN DRIVES, IMPERIAL				OPTIONAL ALLEN DRIVES, METRIC				SHORT REACTION ARM FOR ALLEN DRIVES		
	Model Number	Hexagon Size (inch)	Maximum Torque (Nm)	Model Number	Dim. B1 (mm)	Hexagon Size (mm)	Maximum Torque (Nm)	Model Number	Dim. B1 (mm)	Model Number	Dimensions (mm) C1 H1
S1500 (1898 Nm)	1/2	481	SDA15-008	66	14	644	SDA15-14	66	SRA15	67,5	65
	5/8	936	SDA15-010	67	17	1152	SDA15-17	68			
	3/4	1620	SDA15-012	71	19	1607	SDA15-19	70			
	7/8	1898	SDA15-014	74	22	1898	SDA15-22	73			
	1	1898	SDA15-100	77	24	1898	SDA15-24	74			
S3000 (4339 Nm)	5/8	936	SDA30-010	77	17	1152	SDA30-17	77	SRA30	80,0	74
	3/4	1620	SDA30-012	80	19	1607	SDA30-19	79			
	7/8	2569	SDA30-014	83	22	2488	SDA30-22	82			
	1	3830	SDA30-100	86	24	3234	SDA30-24	84			
	1 1/8	4339	SDA30-102	88	27	4339	SDA30-27	85			
	1 1/4	4339	SDA30-104	89	30	4339	SDA30-30	87			
	-	-	-	-	32	4339	SDA30-32	88			
S6000 (8148 Nm)	5/8	936	SDA60-010	85	17	1152	SDA60-17	86	SRA60	91,5	89
	3/4	1620	SDA60-012	89	19	1607	SDA60-19	88			
	7/8	2569	SDA60-014	92	22	2488	SDA60-22	91			
	1	3830	SDA60-100	95	24	3234	SDA60-24	93			
	1 1/8	5457	SDA60-102	97	27	4603	SDA60-27	94			
	1 1/4	7484	SDA60-104	98	30	6311	SDA60-30	96			
	-	-	-	-	32	7660	SDA60-32	97			
S11000 (14.914 Nm)	1 1/4	7484	SDA110-104	115	30	6311	SDA110-30	112	SRA110	127,5	106
	1 3/8	9958	SDA110-106	117	32	7660	SDA110-32	114			
	1 1/2	12.928	SDA110-108	118	36	10.901	SDA110-36	117			
	1 5/8	14.914	SDA110-110	122	41	14.914	SDA110-41	121			
	1 3/4	14.914	SDA110-112	125	46	14.914	SDA110-46	127			
S25000 (34.099 Nm)	1 1/2	12.928	SDA250-108	141	36	10.901	SDA250-36	140	SRA250	158,5	135
	1 5/8	16.433	SDA250-110	145	41	16.107	SDA250-41	144			
	1 3/4	20.520	SDA250-112	148	46	22.744	SDA250-46	148			
	1 7/8	25.245	SDA250-114	149	50	29.211	SDA250-50	151			
	2	30.635	SDA250-200	151	55	34.099	SDA250-55	154			
	2 1/4	34.099	SDA250-204	154	60	34.099	SDA250-60	158			
	-	-	-	-	65	34.099	SDA250-65	161			
	-	-	-	-	70	34.099	SDA250-70	164			
	-	-	-	-	75	34.099	SDA250-75	168			
	-	-	-	-	85	34.099	SDA250-85	175			

Accessories for S-Series Torque Wrenches

TSP-Series, Pro Series Swivels

- Featuring Tilt and Swivel technology
- 360° X-axis and 160° Y-axis rotation
- Increases tool fit in restricted access areas
- Simplifies hose placement
- Includes male and female Spin-On couplers.

**TSP
RTE
SRS
Series**

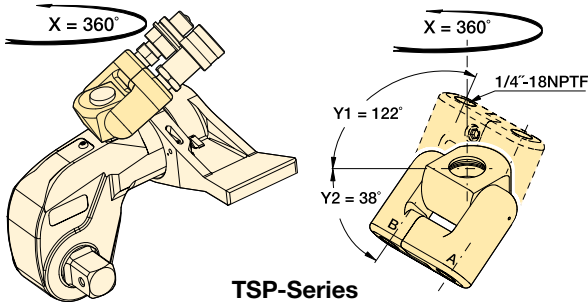

TSP-Series

For Torque Wrench Model Number	Model Number	Maximum Pressure (bar)	 (kg)
S1500, S3000	TSP100A	690	0,2
S6000, S11000, S25000	TSP200A	690	0,2

To order an S-series wrench fitted with the TSP swivel, add suffix "P" to the model number. Example: **S1500P**. TSP-swivel include male (TH-630) and female (TR-630) couplers.

RTE-Series, Reaction Tube Extensions

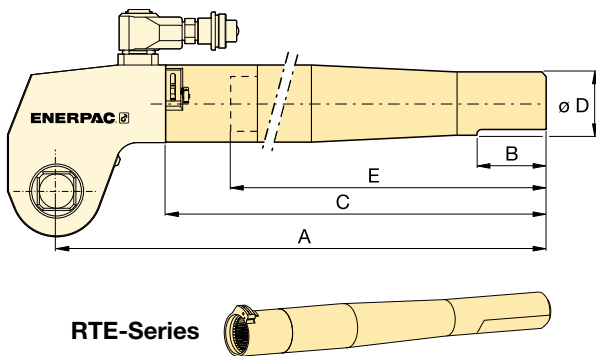

RTE-Series

- Full torque rated
- Increases tool fit in restricted access areas.

For Torque Wrench Model Number	Model Number	Dimensions (mm)					 (kg)*
		A	B	C	D	E	
S1500	RTE15	706	152	636	58	600	4,6
S3000	RTE30	733	152	647	57	600	5,5
S6000	RTE60	747	152	659	65	600	7,7
S11000	RTE110	769	152	675	76	600	11,2
S25000	RTE250	813	152	685	100	600	17,3

* Weights indicated are for the accessories only and do not include the wrench.

SRS-Series, Extended Reaction Arms

- Lightweight interchangeable design.

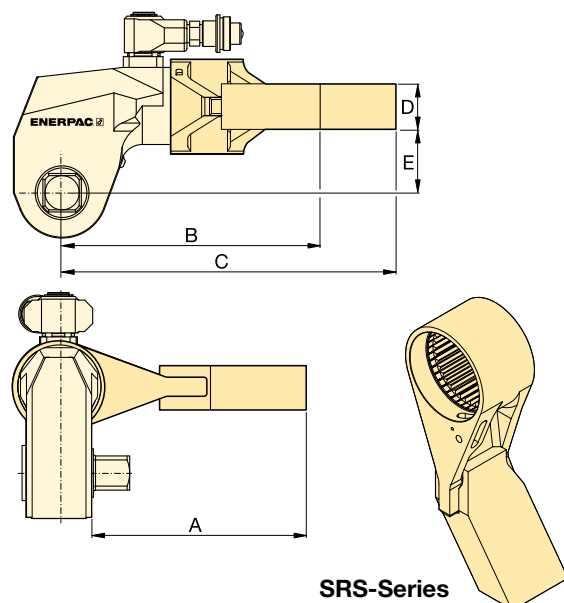

SRS-Series

For Wrench Model	Max. Torque (Nm)	Model Number	Dimensions (mm)					 (kg)*
			A	B	C	D	E	
S1500	1801	SRS151	97	87	128	24	34	0,8
	1641	SRS152	122	98	139	24	34	1,0
	1533	SRS153	147	109	150	24	34	1,2
S3000	3918	SRS301	111	104	170	34	48	1,6
	3712	SRS302	137	119	185	34	48	2,0
	3574	SRS303	162	133	200	34	48	2,5
S6000	7842	SRS601	148	134	198	39	62	2,3
	7454	SRS602	173	149	213	39	62	2,7
	7175	SRS603	198	163	228	39	62	3,4
S11000	14.650	SRS1101	151	158	233	46	76	4,4
	13.957	SRS1102	176	173	248	46	76	5,1
	13.391	SRS1103	201	187	262	46	76	5,8
S25000	33.538	SRS2501	183	225	314	50	100	7,6
	32.049	SRS2502	208	240	329	50	100	8,4
	30.750	SRS2503	233	254	344	50	100	10,0

* Weights indicated are for the accessories only and do not include the wrench.