

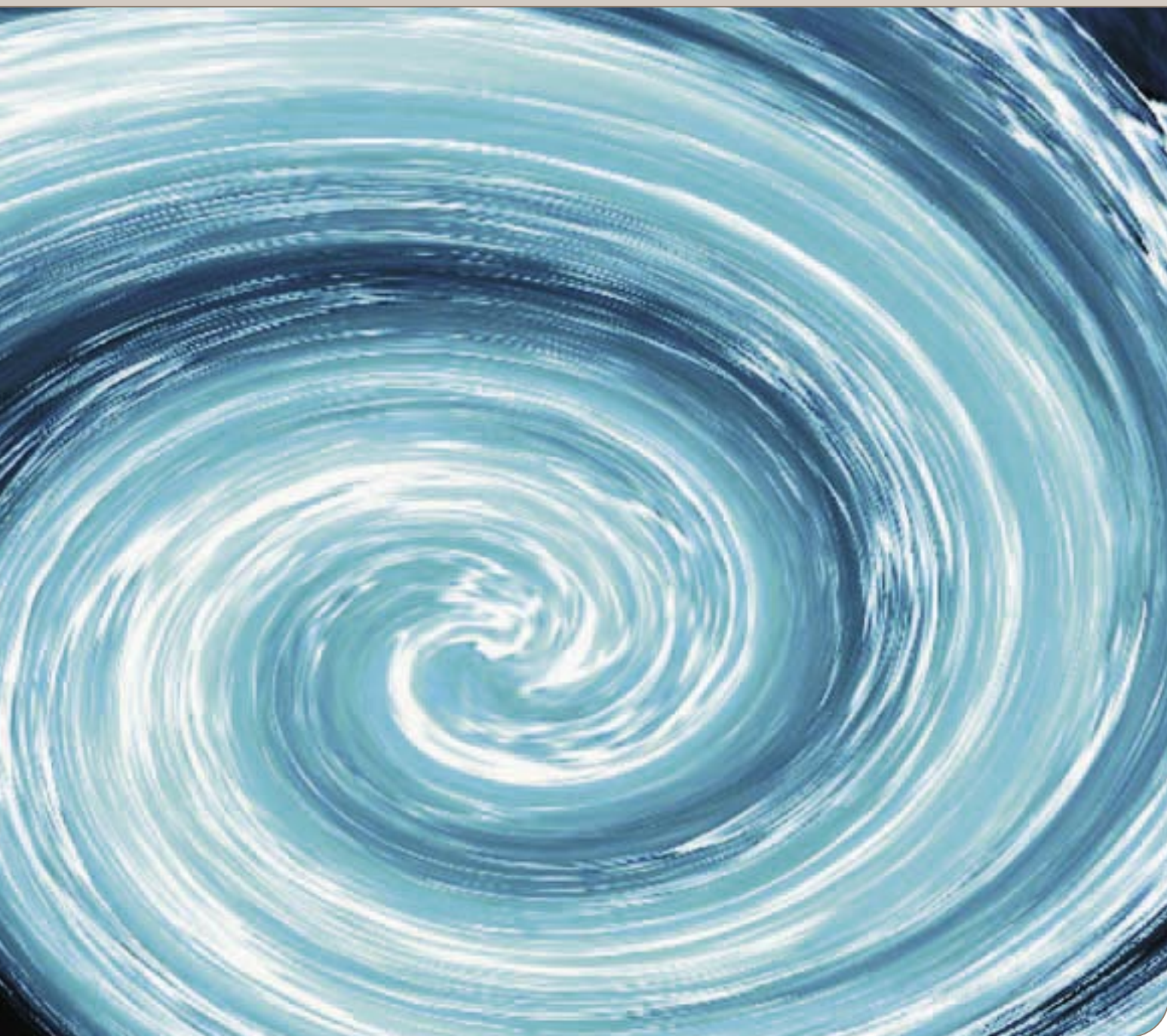

## Alfa Laval – decanter centrifuge technology

Separating solids from liquids



Separating solids from liquids plays a key role in countless industrial processes.

Decanter centrifuges from Alfa Laval perform this crucial function exceptionally well.



# Working principles

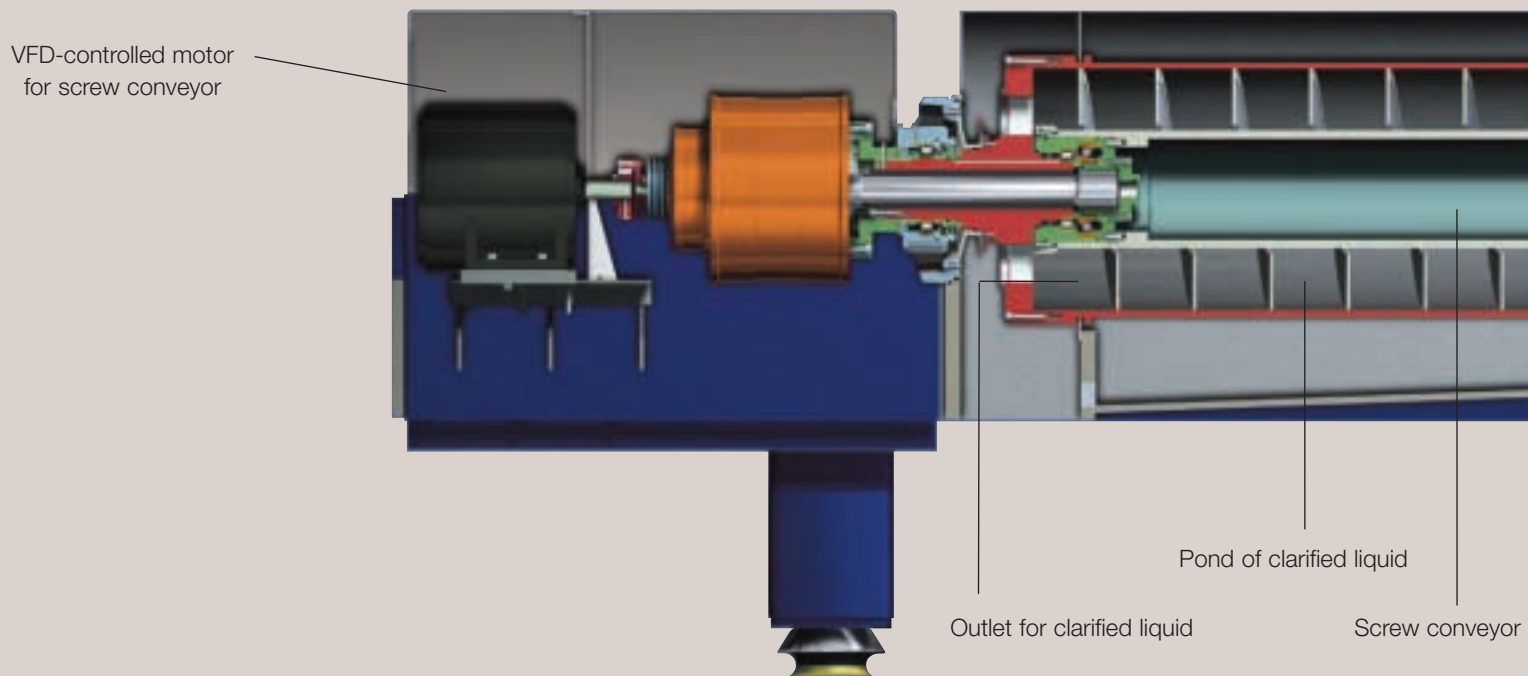

## Continuous separation

Virtually all branches of industry need to separate solids from liquids at some point in their manufacturing processes. Alfa Laval has more than fifty years of experience in meeting this requirement using decanter centrifuge technology. The decanter centrifuge is based on the simple idea of a clarifier or settling tank, in which particles, sediment and solids gradually fall to the bottom due to the force of gravity.

## Accelerating the process

However, such clarification is an extremely slow process and was not able to meet industry's needs for more rapid, controllable results.

The idea behind the development of the decanter centrifuge was therefore to provide the continuous mechanical separation of liquids from solids, to keep pace with modern industrial demands.

In essence, a centrifuge is a clarifier whose base is wrapped around a

centre line. Rotating this unit rapidly means that the effect of gravity is replaced by a centrifugal force – the effect of which can be up to 4000 times greater.

This force is then used to separate solids from liquids efficiently in a manner that is easy to control. Depending on the particular configuration and surrounding equipment, a decanter centrifuge can be used to separate a wide range of different solids from one or two liquid phases, on a continuous basis.

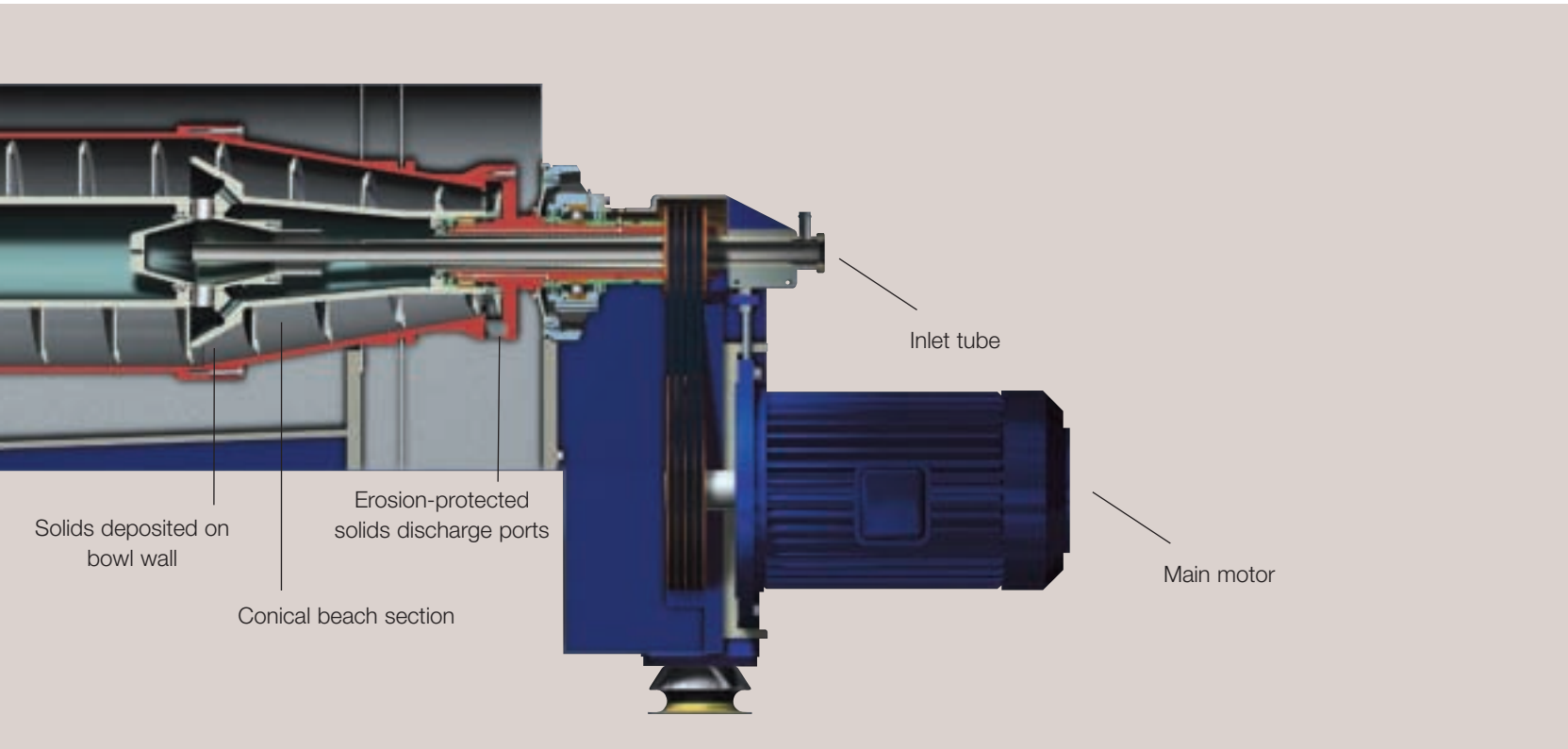
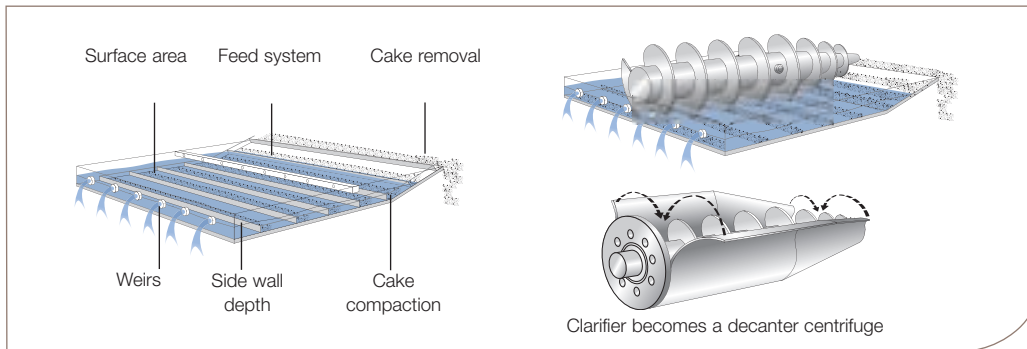

### How a decanter centrifuge works

A decanter centrifuge separates solids from one or two liquid phases in one single continuous process. This is done using centrifugal forces that can be well beyond 3000 times greater than gravity.

When subject to such forces, the denser solid particles are pressed outwards against the rotating bowl wall, while the less dense liquid phase forms a concentric inner layer. Different dam plates are used to vary the depth of the liquid – the so-called pond – as required.

The sediment formed by the solid particles is continuously removed by the screw conveyor, which rotates at a different speed than the bowl. As a result, the solids are gradually “ploughed” out of the pond and up the conical “beach”.

The centrifugal force compacts the solids and expels the surplus liquid. The dried solids then discharge from the bowl. The clarified liquid phase or phases overflow the dam plates situated at the opposite end of the bowl. Baffles within the centrifuge casing direct the separated phases into the correct flow path and prevent any risk of cross-contamination.

The speed of the screw conveyor may be automatically adjusted by use of the variable frequency drive (VFD) in order to adjust to variation in the solids load.

# The key to exceptional performance

## Wide-ranging performance

Alfa Laval decanter centrifuges provide exceptional performance when separating solids from liquids, and make it possible to do so continuously, efficiently and controllably.

Decaners are invariably the first choice to meet such separation needs by virtue of their high reliability, continuous operation, low capital cost/capacity ratio and low maintenance costs.

Alfa Laval decanter centrifuges are designed to handle a wide range of solid particles with diameters from 5 mm to a few microns.

Decanter units can also handle slurries with a solid content from as low as 0.1% w/w to more than 65% w/w.

Decanter centrifuges can accept variations in the feed more effectively than other types of centrifuge or separation equipment.

## Performance criteria

Five crucial factors determine the performance of decanter centrifuges:

- the centrifugal force required for sedimentation of the solids
- the clarification area necessary to “capture” the solids
- the differential speed required to transport the solids out of the decanter
- the hydrodynamic design, which determines the exact parameters for the turbulence
- the design of the conveyor and beach sections, which are important for efficient solids transportation.

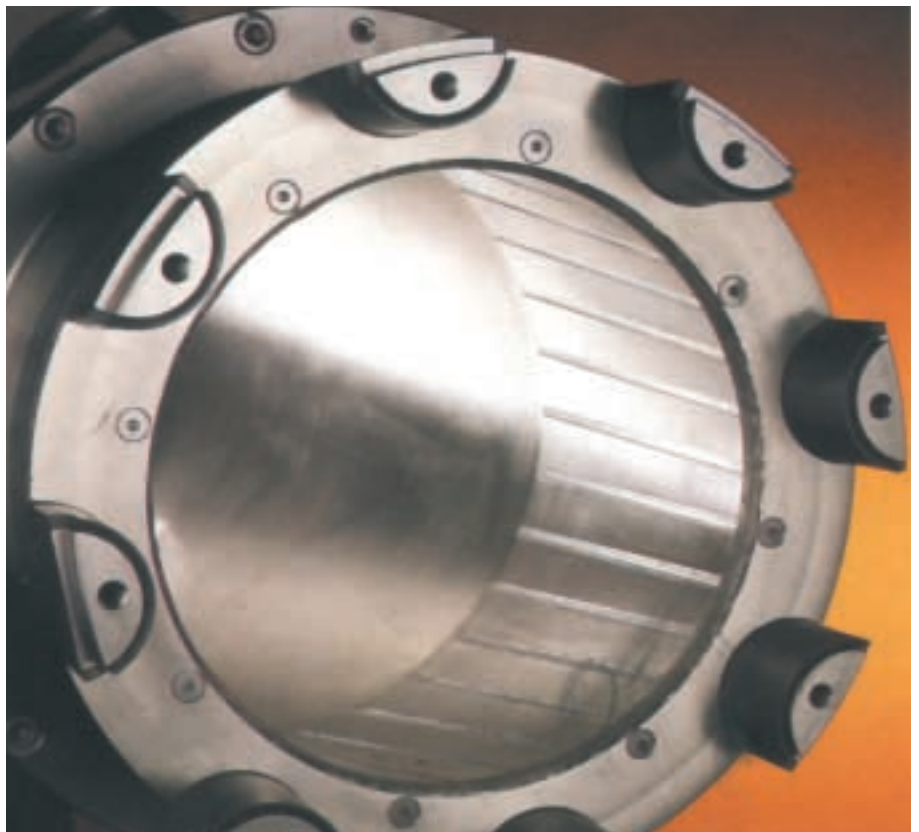

In specifying a decanter centrifuge for a particular application, a series of other specific design considerations has to be taken into account:

- the pitch of the conveyor
- feed zone design
- beach angle
- bowl surface
- abrasion resistance
- materials used in construction.

## The four main sections

Alfa Laval decanter centrifuges feature four main sections, each optimized for maximum performance.

### Inlet zone

The inlet zone accelerates the feed slurry up to the speed of the bowl. A properly designed inlet zone keeps any degradation of the feed solids to a minimum as well as avoiding disturbance of the sediment in the bowl.

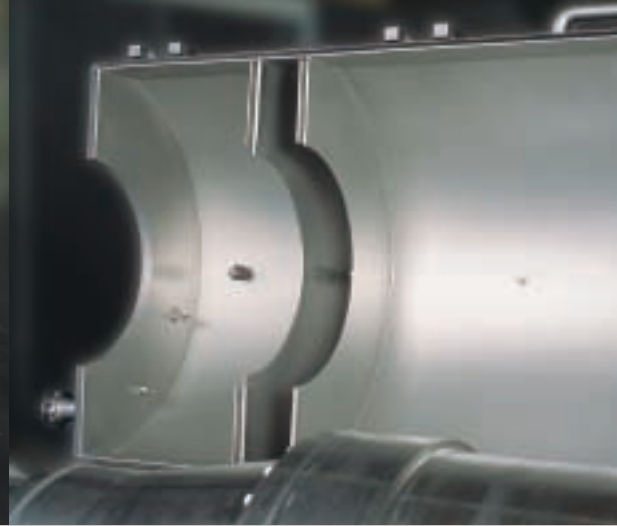

A number of feed zone specifications are available for Alfa Laval decanter centrifuges, each designed to ensure maximum performance in conjunction with a specific process.

### Screw conveyor

The key to good decanter performance lies in the efficient, effective scrolling of the sedimented solids. The design of the screw conveyor is therefore crucial.

Alfa Laval has the expertise needed to match the demands involved in specific industrial processes with specific configurations of flight pitch, lead angle and differential speed, in order to secure the best possible results.

### Solids discharge section

Depending on the application, the consistency of the separated solids can vary from a dry powder to a paste. The configuration of the discharge zone is therefore chosen to enable such “cakes” to exit as effectively as possible.

Innovative Alfa Laval design enables erosion-prone components used in the solids discharge zone to be replaced on site at low cost and with a minimum of disturbance to production.



### Liquid discharge section

In a two-phase decanter, the liquid level is regulated by dam plates. When operating in a three-phase mode, each phase discharges over a set of dam plates into separate baffled compartments in the casing. In certain applications, a centripetal pump discharge that utilizes the pressure head developed by the rotating liquid phase is used to pump the liquid from the decanter.

## Liquid phase outlet

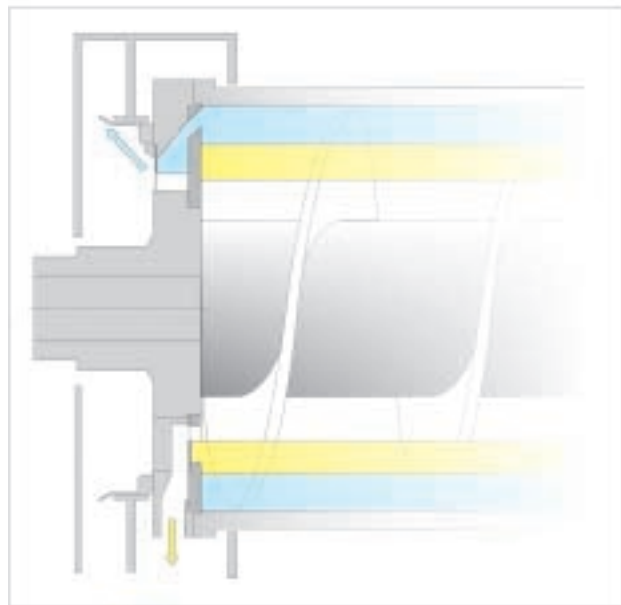
Three-phase design



 Light liquid phase outlet  
 Heavy liquid phase outlet

Paring disc design

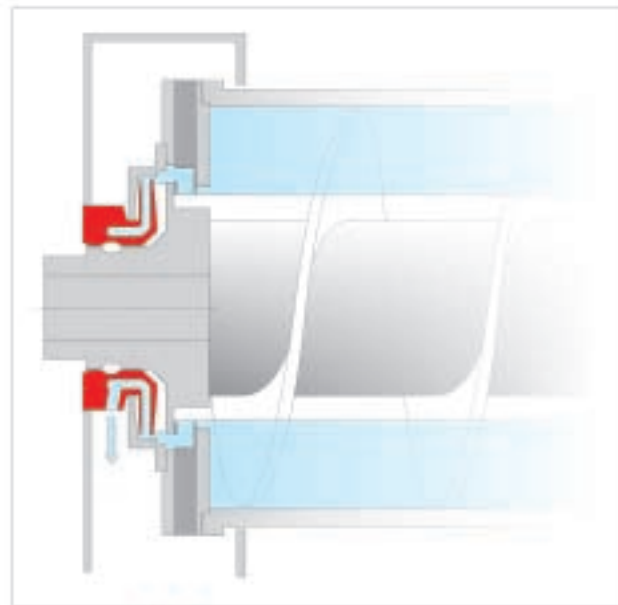

 Liquid outlet

# Benefits and features

## The Alfa Laval difference

The ability to separate the liquid and solid components of often highly complex, high-value processing streams – and to do so with meticulous control, low cost and high reliability – requires decanter centrifuge technology that is second to none.

When the profitability of an entire process is at stake, it is important that the customer has a partner that can be relied on to meet the highly complex demands associated with modern industrial separation.

## Experience counts

Alfa Laval has more than fifty years of practical experience with the design and manufacture of high performance decanter centrifuges.

This puts us in a unique position to translate customer requirements into efficient, reliable machine design and solutions.



And with facilities all over the world, Alfa Laval is in a position to provide customers with superior products, superior service and superior results at any location.

## Research and development

Alfa Laval conducts extensive ongoing R&D into all the technologies involved in the design and operation of decanter centrifuges.

Our know-how and specialist process experience put us in a unique position to match the exact needs of each customer and each particular application and installation.

## Materials technology

Alfa Laval uses high-grade stainless steel for all parts that come into contact with the process, in order to avoid any risk of the corrosion associated with the use of carbon steel. Corrosion leads to product contamination, lack of balance, high maintenance and lengthy down time.







Ease of maintenance and minimum down time are important for users of decanter centrifuges. Rotating components of Alfa Laval decanter centrifuges exposed to high stress are therefore machined from high-strength centrifugally cast stainless steel. This ensures castings with a uniform grain structure free from flaws and defects as well as a completely weld-free finished component. The results are maximum strength, unparalleled reliability and a long service life.

In decanter centrifuges, the optimal choice of materials for each component is crucial for success.

#### **Abrasion resistance**

Wear caused by the abrasive action of solids affects both the performance and service life of all centrifuges. Alfa Laval metallurgists identified this wear as the result of low stress scratching abrasion and were therefore able to develop ways of eliminating its effects.

All wear-prone areas of Alfa Laval centrifuges – the feed zone, solids discharge output zone, bowl and scroll – are therefore protected by abrasion-resistant material, selected to match the pattern of wear in each particular industrial process.



#### **Seal technology**

Special casing seals capable of dealing with pressure differentials are required wherever the processing involves solvents or toxic materials. The types of seals used, and the details of their design, depend on the requirements associated with each particular process. Continual refinement of the seal technology used in Alfa Laval decanter centrifuges is ensured by our technological resources. This is an area where Alfa Laval expertise and experience make a key difference.



# Benefits pay off

## Applications

After fifty years of experience with decanter centrifuges, Alfa Laval has reference installations that are second to none, across a wide range of industries.

### Process industry applications

#### Mineral processing industry

Kaolin clay and calcium carbonate processing, bentonite and titanium dioxide manufacturers

#### Oil/gas exploration and petrochemical industry

Oil and gas exploration, oil refineries and related industries, lubricating oil additives and waste oil stream recycling

#### Organic chemical industry

Organic intermediate and end products

#### Polymer industry

Thermoplastics including PVC, polypropylene, polystyrene, synthetic rubber and fibres

#### Inorganic chemical industry

Bleaching agents, acids, silica products and fertilizers

#### Ethanol production

Processing of grain alcohol spent wash and molasses fermenter residues

#### Starch processing

Based on wheat, maize, tapioca, cassava and potatoes

#### Waste recycling

Recovery and recycling of waste streams from the sectors listed above





## Food applications

### Animal protein

Fish and meat by-product processing  
Surimi processing  
Edible protein recovery

### Brewery

Recovery of extract, wort and yeast

### Coffee and tea

Extraction of instant coffee and tea

### Dairy

Recovery of casein, lactose, whey fines and cheese fines

### Edible oil

Clarification of palm oil, olive oil and pressed seed oil

### Juice

Extraction from fruit, berries and vegetables

### Pectin

Recovery of extracted pectin

### Vegetable protein

Extraction from soybeans, oil seeds and leguminous crops

### Wine

Must and wine clarification



# Nonstop Performance

## Service counts



In modern industrial processes, efficient, well-planned service plays an important part in maintaining profitable operations.

### Full control

Alfa Laval operates with a highly sophisticated Nonstop Performance concept made possible by our worldwide network of service and spare parts distribution centres in more than fifty countries throughout the world.



Alfa Laval has full control over the entire supply chain, which means that we can provide customers with response times, availability and lead times that are second to none.

**Service when it fits in**

The service requirements for Alfa Laval decanter centrifuges are minimal, and planned preventive maintenance is the key to making sure this always remains the case.

Alfa Laval's worldwide service capabilities and vast experience with the contract maintenance and service of decanter centrifuges ensure that any service work required involves the absolute minimum of disturbance to operations.

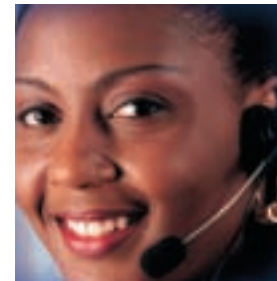





## **Alfa Laval in brief**

Alfa Laval is a leading global provider of specialized products and engineered solutions.

Our equipment, systems and services are dedicated to helping customers to optimize the performance of their processes. Time and time again.

We help our customers to heat, cool, separate and transport products such as oil, water, chemicals, beverages, foodstuffs, starch and pharmaceuticals.

Our worldwide organization works closely with customers in almost 100 countries to help them stay ahead.

## **How to contact Alfa Laval**

Up-to-date Alfa Laval contact details for all countries are always available on our website at [www.alfalaval.com](http://www.alfalaval.com)

